

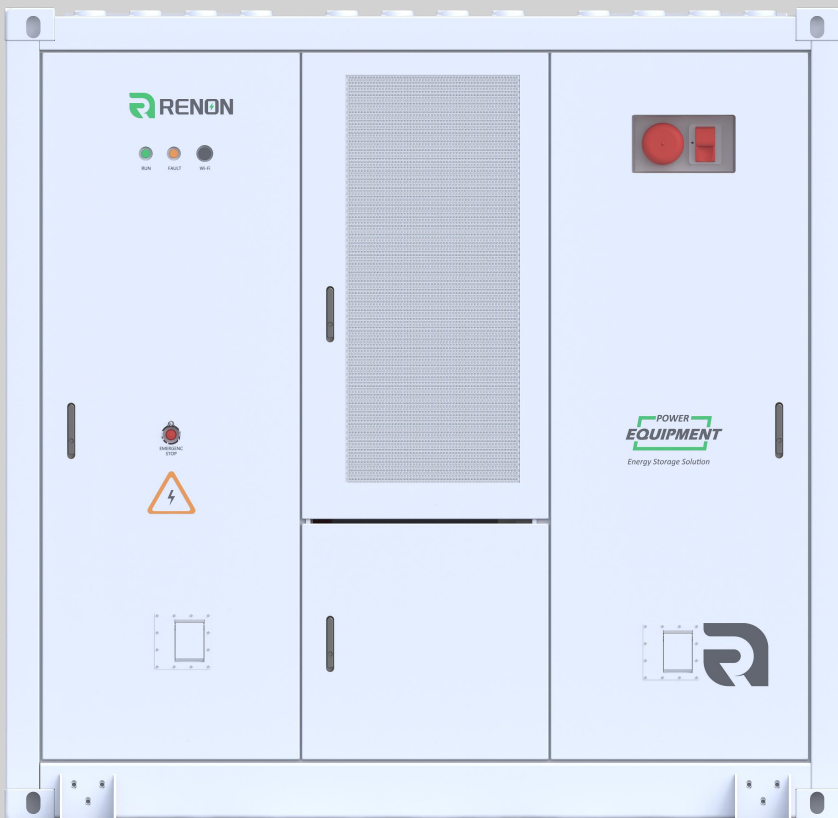

Technical Agreement

R-SM1672860A1-US

Smart Matrix A



E-mail: support@renon-usa.com

Buyer:

Supplier:

2025 1ST EDITION

© Renon Power USA LLC.

All rights reserved. Specifications are subject to change without notice.

Renon Power

We Care About Sustainability

With our own R&D team and automatic production factory, we are dedicated to delivering innovative, reliable, and affordable energy storage solutions to global customers.

At Renon, we believe that sustainable energy is the future. We are passionate about reducing carbon emissions and preserving our planet for future generations. That's why we invest heavily in research and development, leveraging the latest technologies to design and manufacture energy storage systems that are efficient, scalable, and adaptable.

Our products are designed to meet the needs of a wide range of applications, from residential and commercial buildings to industrial facilities and utility-scale projects. Whether you're looking to reduce your energy bills, increase your energy independence, or support your sustainability goals, Renon has the right solution for you.

Our commitment to quality and customer satisfaction is unwavering. We work closely with our clients to understand their unique needs and provide customized solutions that meet or exceed their expectations. We also provide comprehensive technical support, maintenance, and warranty services to ensure that our customers get the most out of their investment.

[Join us on our mission to make renewable energy within reach.](#)

PROVIDE **INNOVATIVE,**
RELIABLE, AND
AFFORDABLE ENERGY
STORAGE SOLUTIONS
TO CUSTOMERS
WORLDWIDE.



CONTENTS

1. GENERAL PART - 1 -

1.1 SCOPE OF SUPPLY BY THE SUPPLIER - 1 -

1.2 WORK OF THE PROJECT SITE PERFORMED BY THE BUYER - 2 -

1.3 BUYER’S RESPONSIBILITY FOR SITE PREPARATION - 2 -

1.4 OTHER SITE-SPECIFIC REQUIREMENTS - 2 -

2. TERMS AND DEFINITIONS - 3 -

2.1 BATTERY SYSTEM - 3 -

2.2 POWER CONVERSION SYSTEM (PCS) - 3 -

2.3 BATTERY MANAGEMENT SYSTEM (BMS) - 3 -

2.4 UNINTERRUPTIBLE POWER SUPPLY SYSTEM (UPS) - 3 -

2.5 ENERGY MANAGEMENT SYSTEM (EMS) - 3 -

2.6 FIRE SUPPRESSION SYSTEM - 4 -

2.7 LIQUID COOLING SYSTEM - 4 -

2.8 BATTERY ENERGY STORAGE SYSTEM (BESS) - 4 -

2.9 SOC (STATE OF CHARGE) & SOH (STATE OF HEALTH) - 4 -

2.10 NOMINAL ENERGY & USABLE ENERGY - 4 -

2.11 ON-GRID & OFF-GRID MODE - 4 -

3. TECHNICAL SPECIFICATIONS - 5 -

3.1 SCOPE OF SYSTEM DESIGN - 5 -

3.1.1 Product Parameters - 5 -

3.2 CHARGE AND DISCHARGE LIMITATIONS - 6 -

3.2.1 Charge and Discharge Power Limits - 6 -

3.2.2 Temperature and SOC-Based Charge/Discharge Limitations - 6 -

3.3 OPERATION CONDITION AND ENERGY RETENTION - 7 -

3.3.1 Operation & Storage Environment Conditions	- 7 -
3.3.2 Energy Retention Performance	- 8 -
3.3.3 Transportation and Handling Requirements	- 8 -
3.4 THE STRUCTURE AND TOPOLOGY	- 9 -
3.4.1 Internal Structure	- 9 -
3.4.2 Application Topology	- 10 -
3.5 ELECTRICAL WIRING DIAGRAM	- 11 -
3.6 EXTERNAL INTERFACES	- 11 -
3.6.1 AC Output Interface	- 11 -
3.6.2 Auxiliary Power Supply Interface	- 11 -
3.6.3 Communication Interface	- 12 -
3.6.4 Grounding Interface	- 12 -
3.7 FIRE SUPPRESSION SYSTEM	- 13 -
3.8 INSTALLATION SITE ENVIRONMENTAL REQUIREMENTS	- 14 -
3.8.1 General Environmental Requirements	- 14 -
3.8.2 Site Selection Considerations	- 14 -
3.8.3 Installation and Spacing Requirements	- 14 -
3.8.4 Handling and Installation Precautions	- 15 -
4. EMS CONTROL	- 15 -
4.1 CONTROL MODES AND AUTHORITY	- 15 -
4.2 AUTOMATIC AND MANUAL CONTROL PRIORITY	- 16 -
4.3 CORE FUNCTIONS OF THE LOCAL EMS	- 16 -
5. INSTALLATION INSTRUCTION	- 16 -
6. REVISION TABLE	- 17 -

1. General Part

This Technical Agreement applies to the **RENON Smart Matrix A (Model: R-SM1672860A1-US)** all-in-one AC/DC battery energy storage system (BESS). The agreement defines the **technical specifications, scope of supply, and division of responsibilities** to ensure mutual understanding between Buyer and supplier regarding product performance and compliance requirements.

The agreement specifically outlines:

- Product specifications, including technical parameters, system functionality, and performance.
- Scope of supply detailing provided equipment, components, and accessories.
- Clear delineation of responsibilities between the supplier and the Buyer.

This Agreement shall be mutually reviewed, confirmed, and agreed upon by both parties prior to finalizing the order. Issues not explicitly addressed herein will be resolved through mutual consultation and supplementary documentation.

1.1 Scope of Supply by the Supplier

The Supplier shall provide the following equipment and components as part of the Smart Matrix A:

Equipment	Description	Quantity	Remarks
Container	The integrated system container combines battery system, PCS, BMS, EMS, UPS system, liquid cooling system, and fire suppression system into a unified enclosure.	1 set	Includes all core components for energy storage and safety

Notes: Any additional equipment required for integration with external systems shall be provided by the Buyer unless otherwise specified.

1.2 Work of the Project Site Performed by the Buyer

The Buyer is responsible for the following tasks at the project site:

1.2.1 Transportation & Installation

- Installing the Smart Matrix A in the designated location.
- Lifting, positioning, and securing the Smart Matrix A at the site.
- Ensuring proper ventilation and cooling in the installation area.

1.2.2 Electrical Connections

- Connecting all external cables as required in *section 3.6*.
- Ensuring proper battery module connections inside the system.

1.2.3 Commissioning & Integration

- Providing necessary external power and communication infrastructure for the ESS.
- Cooperating with the supplier during system debugging and final testing.

1.3 Buyer's Responsibility for Site Preparation

- The foundation must be levelled and prepared in accordance with engineering specifications to support the weight of the system.
- Adequate drainage must be implemented to prevent water accumulation around the system.
- Proper earthing and grounding must be established to meet safety requirements.
- If the installation site exceeds the specified environmental conditions, the Buyer must implement additional protective measures, such as shading, enclosures, or environmental controls.

1.4 Other Site-Specific Requirements

- Compliance with local regulations, safety codes, and grid connection standards.
- Any additional work not specified in the supplier's scope shall be performed by the Buyer.

Notes:

- The supplier will provide technical support and software debugging during commissioning, but the Buyer must ensure that all necessary site conditions are met before testing.
- Any additional installation requirements shall be agreed upon separately.

2. Terms and Definitions

2.1 Battery System

A collection of battery system that store electrical energy, composed of:

- **Battery Cell:** The smallest unit of energy storage in the system.
- **Battery Module:** A combination of battery cells electrically connected in a protective casing.
- **Battery Rack:** A structure containing multiple battery modules to form a complete energy storage system.

2.2 Power Conversion System (PCS)

A bi-directional inverter/rectifier that converts power between DC (battery) and AC (grid/load), managing charge, discharge, and grid interaction.

2.3 Battery Management System (BMS)

Monitors and controls the battery's state of charge (SOC), state of health (SOH), temperature, and voltage to ensure safe operation and optimal performance. The BMS system adopts a three-tier control architecture, consisting of:

- Primary **BMU (Battery Monitoring Unit)** for cell-level data acquisition;
- Secondary **BC (Battery Controller)** for pack-level management and protection;
- Tertiary **BA (Battery Aggregator)** for multi-cluster coordination and external system interaction, forming a hierarchical control structure.

2.4 Uninterruptible Power Supply System (UPS)

UPS (Uninterruptible Power Supply) is an uninterruptible power supply device. In the event of a mains power failure, the control module of the energy storage system (ESS) can draw power from the UPS to ensure continuous operation of the control module. The UPS system in the RENON Smart Matrix A consists of the following two components:

- **UPS Host Unit:** The core device that immediately switches to UPS inverter mode after a mains power failure, ensuring the control module inside the energy storage cabinet receives continuous power supply.
- **UPS Backup Battery Pack:** An energy storage component that provides emergency power to the UPS host unit during mains power failure, with a backup duration capable of supporting the energy storage system's control module for 60 minutes of continuous operation.

2.5 Energy Management System (EMS)

A system that enables **remote and local monitoring of the BESS**, facilitating real-time operation management and performance tracking. It consists of:

- Communication Interface: **Supports** Modbus (TCP/IP) or other industry-standard protocols to **integrate with external controllers and grid management systems.**
- Local Touchscreen Display: A device-mounted HMI (Human-Machine Interface) **for direct system control and monitoring.**
- Cloud-Based Software Platform: **Provides** remote monitoring, historical data analysis, and system diagnostics **via an internet connection.**

2.6 Fire Suppression System

A **built-in safety system** designed to **detect, alarm, and suppress fires** within the BESS. This integrated safety system achieves rapid fire detection and response, ensuring optimal system safety and reliability.

2.7 Liquid Cooling System

A built-in cooling system aim to guarantees precise temperature management to maximize battery lifespan and efficiency.

2.8 Battery Energy Storage System (BESS)

The complete Smart Matrix A **integrated system**, consisting of:

- **Battery System**
- **BMS**
- **Fire Suppression System**
- **UPS**
- **PCS**
- **EMS**
- **Liquid Cooling System**

2.9 SOC (State of Charge) & SOH (State of Health)

- **SOC (State of Charge):** The remaining available energy in the battery, expressed as a percentage of its full capacity.
- **SOH (State of Health):** A measure of the battery's overall condition, indicating how much capacity it retains compared to its original state.

2.10 Nominal Energy & Usable Energy

- **Nominal Energy:** The total rated energy capacity of the battery system.
- **Usable Energy:** The actual energy available for discharge, considering system limitations such as **depth of discharge (DOD)** and safety margins.

2.11 On-Grid & Off-Grid Mode

- **On-Grid Mode:** The BESS operates while connected to the power grid, supporting grid stability and energy management.
- **Off-Grid Mode:** The BESS functions independently of the grid, supplying power to isolated loads when the grid is unavailable.

3. Technical Specifications

3.1 Scope of System Design

The **Smart Matrix A** is an **all-in-one AC/DC BESS** designed within a standard 10-foot container. The system is equipped with **battery system, battery management system (BMS), power conversion system (PCS), energy management system (EMS), uninterruptible power supply system (UPS), fire suppression system, and liquid cooling system**. With a high energy density of **836kW/1672kWh per unit**, connecting **three Smart Matrix A units in parallel** on the AC side can form an industry-standard 5MWh system. This feature ensures flexibility and reliability, making it suitable for both small and large-scale projects.

3.1.1 Product Parameters

Battery System	R-SM1672860A1-US
Cell Type	LFP 3.2V/314Ah
Module Configuration	1P104S
Cluster Configuration	1P416S
Number of Clusters	4
System Energy (kWh)	1672
Nominal Voltage (V)	1331.2
Operation Voltage Range (VDC)	1040~1497.6
Discharge Depth	90% DoD
AC Output	
AC Nominal Output Power (kVA)	836
AC Nominal Voltage (VAC)	690
Power Factor	-1~1
System Characteristic	
Round-Trip Efficiency (Annual Average)	85% ¹
Communication Interface	CAN, RS485, Ethernet
System Certifications	UL 1973, UL 9540, UL 9540A, NFPA 855, NFPA68/69
Thermal Management Mode	Liquid Cooling
Fire Suppression System	Aerosol Extinguishing & Explosion-proof Ventilation
Dimensions (W×D×H)	117.8 × 96.0 × 114.0 in (±0.5 in) 2991 × 2438 × 2896 mm(±10mm)
Weight (Net Weight)	33069 lb (15T) ²
Noise Level@1m	<75dB (A)
IP Rating	IP66 (Main enclosure); IP54 (Thermal system)

* 1 Test Conditions: Ambient temperature of 77°F ±4°F(25°C ±2°C). Prior to testing, the ESS shall be left undisturbed in the test environment for a sufficient period to ensure all components reach thermal equilibrium.

*2 Weight is for reference only and subject to the actual product.

3.2 Charge and Discharge Limitations

The charge and discharge performance of the **Smart Matrix A** is determined by the **EMS**. The system dynamically adjusts charge and discharge power based on **state of charge (SOC), temperature, and BMS protection settings** to ensure safe operation and long-term battery health. The EMS coordinates various factors through hierarchical decision-making, with the logical priority hierarchy as follows: Safety Protection > Battery Hard Constraints > External Power Demand.

Hierarchy	Factor	Logical Description
1	Safety Protection	When a fault signal from the BMS, PCS, or grid is triggered, the EMS immediately terminates charging/discharging (highest priority).
2	Battery Hard Constraints	SOC/SOH/temperature limits provided by the BMS directly restrict the power command range of the EMS.
3	External Power Dispatch	Real-time demands such as power dispatch from third-party EMS are prioritized within safe battery limits.

3.2.1 Charge and Discharge Power Limits

Parameter	R-SM1672860A1-US
Nominal Charge/Discharge Power (kW)	209*4
Maximum AC-side Charge/ Discharge Current (A)	700*1.1

3.2.2 Temperature and SOC-Based Charge/Discharge Limitations

Discharge Current Limitations (Continuous Current in Amperes, A, Single Cluster)

The following table shows the **maximum allowable DC-side discharge current** of a single battery cluster under different SOC and cell temperature conditions:

%/°C	0<SOC<5	5≤SOC<10	10≤SOC<20	20≤SOC<30	30≤SOC<40	40≤SOC<50	50≤SOC<60	60≤SOC<70	70≤SOC<80	80≤SOC<90	90≤SOC<100	SOC=100
-31	0	0	0	0	0	0	0	0	0	0	0	0
-30≤T<-25	0	0	0	0	37	74	112	112	112	112	112	112
-25≤T<-20	0	0	0	37	37	74	112	112	112	112	112	112
-20≤T<-15	0	0	37	74	112	112	112	112	112	112	112	112
-15≤T<-10	0	0	37	74	112	112	112	112	112	112	112	112
-10≤T<-5	37	37	74	112	112	112	112	112	112	112	112	112
-5≤T<0	37	37	112	112	112	112	112	112	112	112	112	112
0≤T<5	37	74	112	112	112	112	112	112	112	112	112	112
5≤T<10	37	74	186	186	186	186	186	186	186	186	186	186
10≤T<15	37	74	186	186	186	186	186	186	186	186	186	186
15≤T<20	37	74	186	186	186	186	186	186	186	186	186	186
20≤T<25	37	74	186	186	186	186	186	186	186	186	186	186
25≤T<30	37	74	186	186	186	186	186	186	186	186	186	186
30≤T<35	37	74	186	186	186	186	186	186	186	186	186	186
35≤T<40	37	74	186	186	186	186	186	186	186	186	186	186
40≤T<45	37	74	157	157	157	157	157	157	157	157	157	157
45≤T<50	37	74	74	74	74	74	74	74	74	74	74	74
50≤T<55	37	37	37	37	37	37	37	37	37	37	37	37
T≥55	0	0	0	0	0	0	0	0	0	0	0	0

Charge Current Limitations (Continuous Current in Amperes, A, Single Cluster)

The following table shows the **maximum allowable DC-side charge current** of a single battery cluster under different SOC and cell temperature conditions:

%/°C	0≤SOC<5	5≤SOC<10	10≤SOC<20	20≤SOC<30	30≤SOC<40	40≤SOC<50	50≤SOC<60	60≤SOC<70	70≤SOC<80	80≤SOC<90	90≤SOC<95	95≤SOC<99	99≤SOC<100	SOC=100
-1≤T<0	0	0	0	0	0	0	0	0	0	0	0	0	0	0
0≤T<5	37	37	37	37	37	37	37	37	37	37	37	0	0	0
5≤T<10	74	74	74	74	74	74	74	74	74	74	74	0	0	0
10≤T<15	74	74	74	74	74	74	74	74	74	74	74	0	0	0
15≤T<20	157	157	157	157	157	157	157	157	157	157	157	157	74	0
20≤T<25	186	186	186	186	186	186	186	186	186	186	186	186	74	0
25≤T<30	186	186	186	186	186	186	186	186	186	186	186	186	74	0
30≤T<35	186	186	186	186	186	186	186	186	186	186	186	186	74	0
35≤T<40	186	186	186	186	186	186	186	186	186	186	186	186	74	0
40≤T<45	157	157	157	157	157	157	157	157	157	157	157	157	74	0
45≤T<50	157	157	157	157	157	157	157	157	157	157	157	157	74	0
50≤T<55	74	74	74	74	74	74	74	74	74	74	74	74	0	0
T≥55	0	0	0	0	0	0	0	0	0	0	0	0	0	0

3.3 Operation Condition and Energy Retention

The **Smart Matrix A** is designed to operate within specific environmental conditions to ensure optimal performance, longevity, and safety. This section outlines the operational requirements, energy retention capabilities, and transportation conditions based on industry standards.

3.3.1 Operation & Storage Environment Conditions

To ensure optimal battery performance, longevity, and safety, the BESS must be operated and stored under the following conditions:

Parameter	Requirement
Operation Temperature	-4~131°F, derating above 104°F; -20~55°C, derating above 45°C
Operation Humidity(RH)	5%~90%, Non-condensing
Storage Conditions	-4~86°F (-20~30°C), 10% to 90% RH Storage ≥30days: SOC (40±3)%, RH<90% (non-condensing)
Altitude Limit	≤13122ft (derating above 9843ft); ≤4000m (derating above 3000m)

- Temperature Impact: If the ambient temperature exceeds 104°F (45°C), the system will automatically reduce power output to prevent overheating.
- Altitude Impact: If installed above 9843ft (3000m), the system efficiency may be reduced due to lower air density affecting cooling performance.

3.3.2 Energy Retention Performance

The **Smart Matrix A** is designed to **retain stored energy efficiently over time**, ensuring reliable performance when needed. The energy retention capabilities are defined based on industry-standard **self-discharge rates and idle consumption**.

Parameter	Retention Performance
Self-Discharge Rate (Monthly, at 77°F/25°C) (Shutdown State)	≤ 0.3%
Energy Retention After 24 Hours (Shutdown State)	≥ 99%

Note:

- Energy loss primarily results from BMS and PCS standby consumption.
- Higher temperatures can accelerate self-discharge rates, which should be considered for long-term storage applications.

3.3.3 Transportation and Handling Requirements

To ensure the safety and integrity of the Smart Matrix A during transportation, the system must comply with international shipping and handling standards.

The Smart Matrix A is not approved for mobile/vehicle-mounted energy storage applications.

Aspect	Requirement
Transportation Mode	Suitable for land and sea transportation
Compliance Standard	UN38.3
Handling Precautions	Must be transported upright; avoid excessive tilting
Packing Standard	Secured with anti-vibration mounts and shock-absorbing materials
Storage During Transit	-4°F to 113°F (-20°C to 45°C) , avoid prolonged exposure to extreme heat or moisture
Base Requirements	Level the base with a spirit level and ensure its surface is within 0.2in(5mm) of the floor level.

3.4 The Structure and Topology

3.4.1 Internal Structure

The internal layout and component positions within the BESS container are shown clearly in the provided layout diagram below. Major system components and their exact locations have been marked directly on the diagram for easy reference during installation, commissioning, and maintenance.

Container color: Light Grey (RAL 7035)

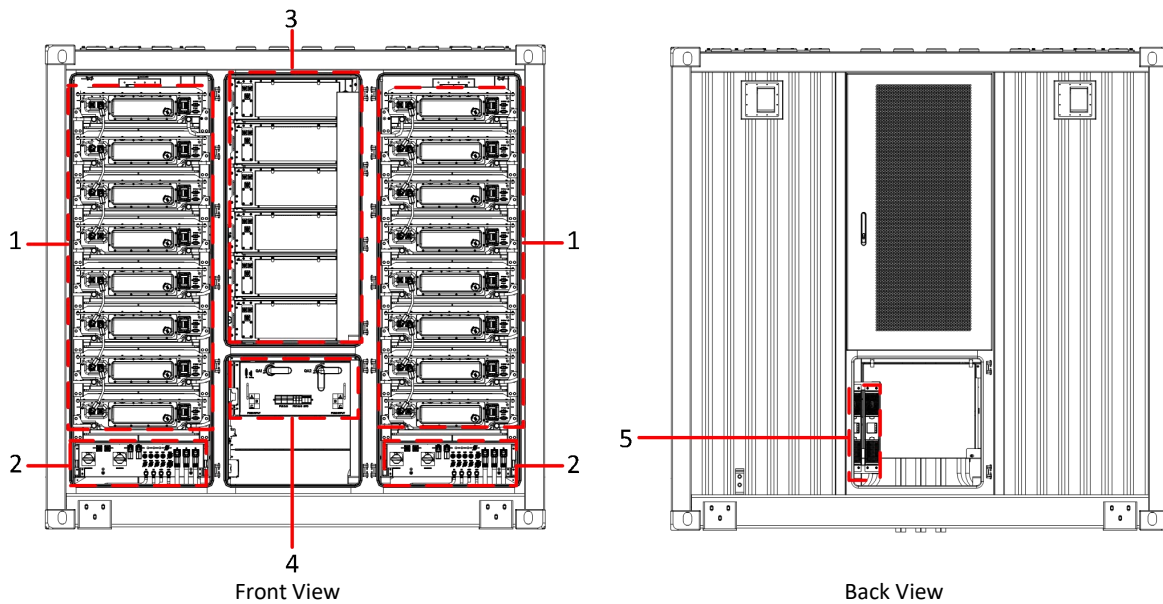

Figure 1 –Smart Matrix A Overall Layout

No.	Component	No.	Component
1	Battery Module	2	PCS
3	Chiller	4	Combiner Box
5	UPS		

3.4.2 Application Topology

The Smart Matrix A supports flexible configurations. The application topology provided clearly demonstrates typical deployment scenarios, including necessary external connections.



*Combiner Cabinet and Communication Cabinet

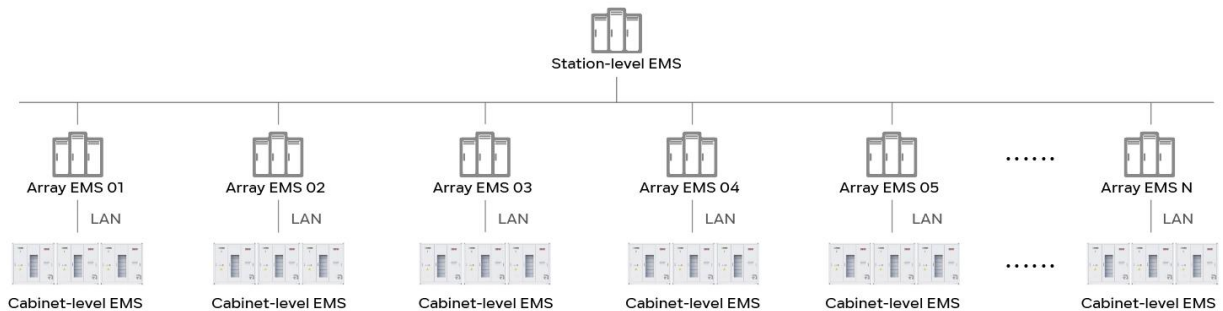

Figure 2– Max.Parallel Connection System Layout & EMS Structure

3.5 Electrical Wiring Diagram

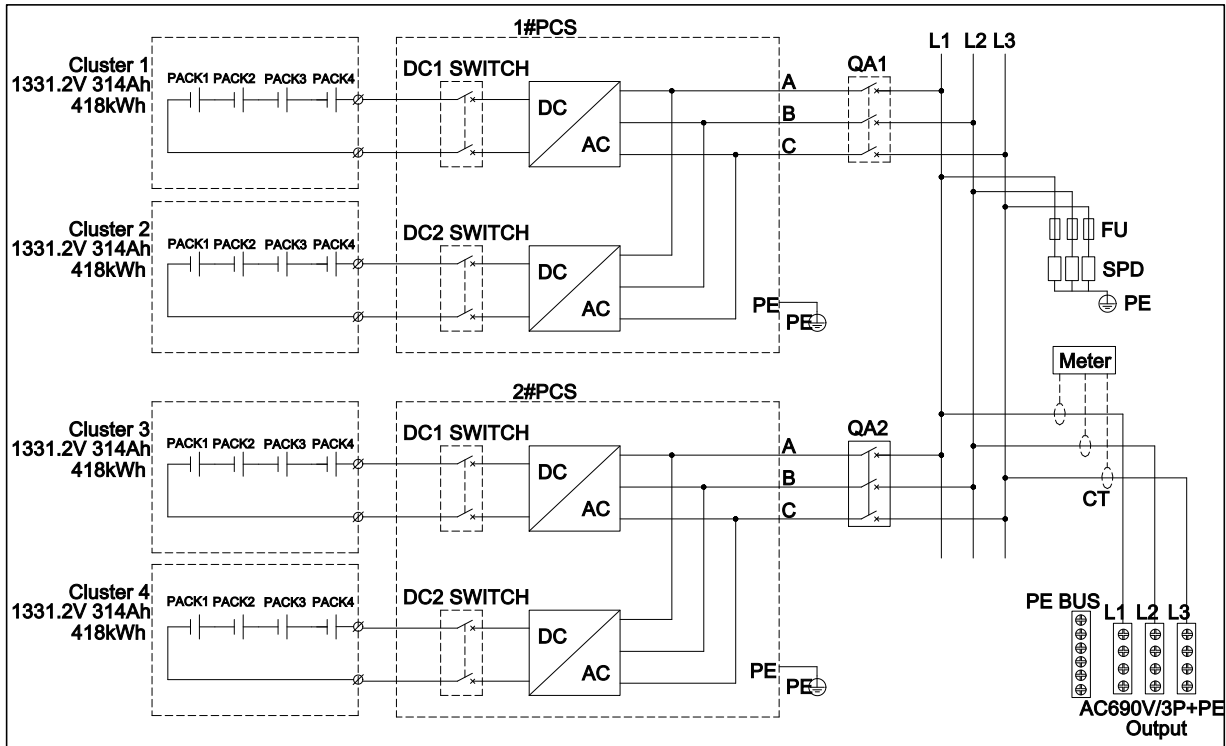

Figure 3 –Electrical Wiring Diagram

3.6 External Interfaces

This section specifies all external interface requirements and standards for the Smart Matrix A.

3.6.1 AC Output Interface

External Interface	Quantity	Description
AC Output Interface	1 set	Three-phase three-wire (L1, L2, L3), AC 690V, 50/60Hz. Recommended cable: Flame-retardant copper; Cable specification: 150mm ² (300Kcmi) per phase, 1000VAC min, 105°C min. Terminal: SC150-12;

3.6.2 Auxiliary Power Supply Interface

The User is required to provide an external auxiliary power supply (AC 380V±15%, Power≥30kW) and connect it to the Smart Matrix A.

External Interface	Quantity	Description
Auxiliary Power Supply Interface	1 set	XTAC(L1/L2/L3/N), AC 380V±15%, Power≥30kW, 50/60Hz; Recommended cable: flame-retardant copper; Cable specification: 16mm ² (6AWG) per phase, 600VAC min, 105°C min; Recommended terminal: SC16-6;

3.6.3 Communication Interface

Each Smart Matrix A container provides communication interfaces for data transmission, monitoring, and external system integration.

External Interface	Quantity	Description
Ethernet (LAN)	1 set	Industrial Ethernet Switch #1: 1) Provides connections to external internet, array EMS, and the host computer. 2) Provides connections to multiple Smart Matrix A units in parallel.
RS485	1 set	Provides connections to meter and the fire suppression system, etc.

Notes:

- Buyer shall ensure the availability of stable network connectivity.
- Supplier provides all internal communication cables and terminations within the BESS container.
- External communication cables from BESS to Buyer's monitoring systems shall be provided by the Buyer.

3.6.4 Grounding Interface

Each Smart Matrix A container is equipped with grounding terminals for external grounding:

External Interface	Quantity	Description	Remark
Enclosure grounding terminal	1 set	Recommended cable: flame-retardant grounding cable with yellow-green insulation. Cable specification: 150mm ² (300Kcmi), 1000VAC	Ground resistance shall be ≤1Ω. The Buyer is responsible for external grounding construction and validation.
Internal ground busbar	1 set	Terminal: SC150-12;	

3.7 Fire Suppression System

The Smart Matrix A is equipped with a comprehensive fire suppression system that utilizes aerosol as the extinguishing medium. This integrated safety system achieves rapid fire detection and response through multiple components including smoke detector, heat sensor, flammable gas sensor, and aerosol fire extinguisher, thereby ensuring optimal system safety and reliability.

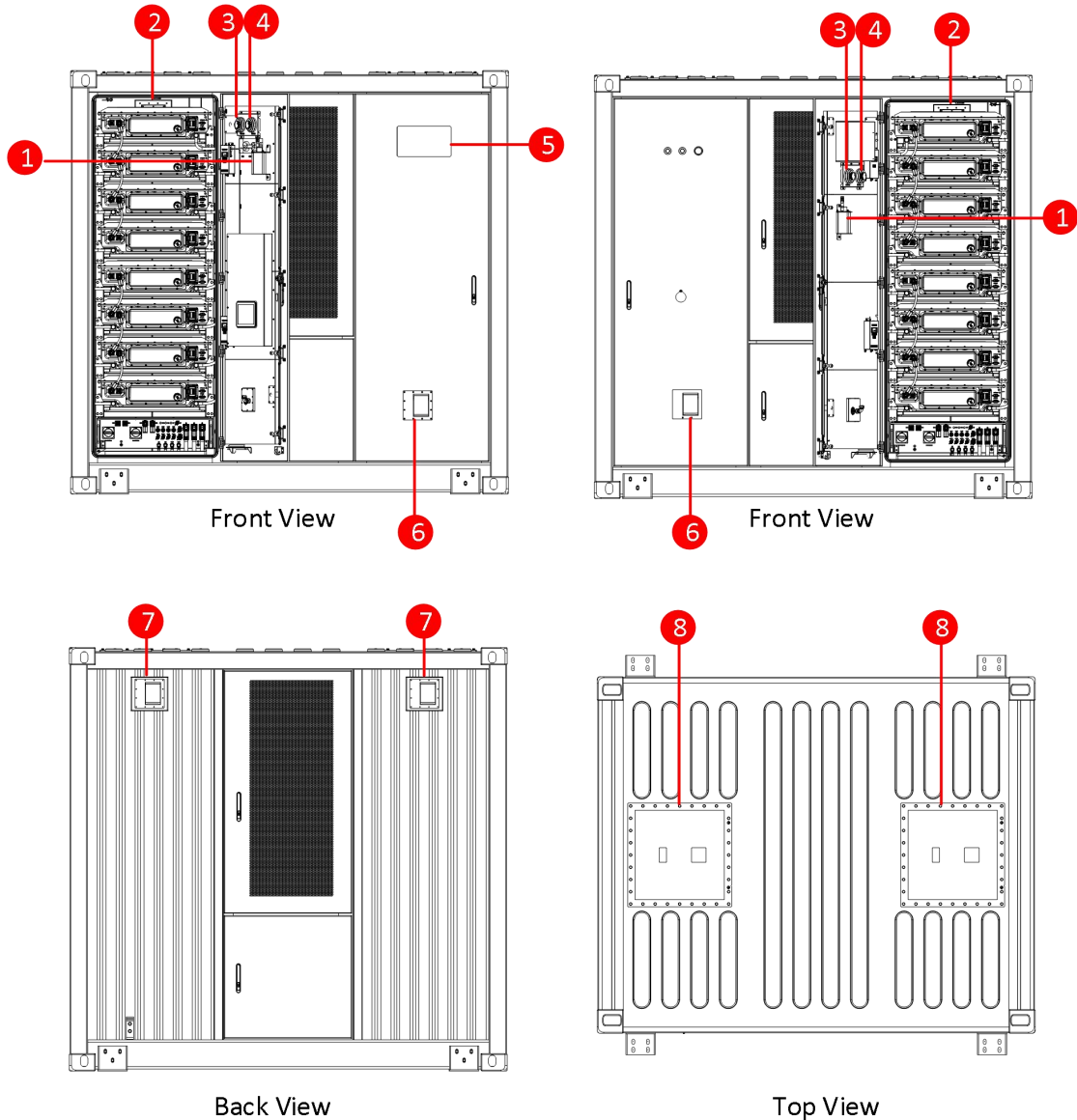

Figure 4 –Detailed Fire Suppression System

Integrated Components and Functions:

No.	Component	No.	Component
1	Aerosol Fire Extinguisher	2	Flammable Gas Sensor
3	Smoke Detector	4	Heat Detector
5	Alarm Bell& Audible and Visual Alarm	6	Intake Fan
7	Exhaust Fan	8	Explosion Vent Panel

Operational Features:

- Automatic detection and activation with no manual intervention required
- Real-time status monitoring accessible via local EMS and remote monitoring systems
- Immediate notifications and alarms upon activation ensuring timely incident response

3.8 Installation Site Environmental Requirements

This section provides essential physical specifications and site installation requirements to ensure smooth onsite planning and installation.

The Buyer must ensure that the installation environment meets the following requirements to ensure the safe and reliable operation of the Smart Matrix A.

3.8.1 General Environmental Requirements

- Ambient Temperature: The installation site should maintain a temperature range of -4°F to 113°F (-20°C to 45°C).
- Relative Humidity: The system should be installed in an environment with a humidity range of 5 to 90%.
- Altitude: The installation site should not exceed an altitude of 13122ft (4000m).

3.8.2 Site Selection Considerations

The **Smart Matrix A** container **should not be installed in:**

- Areas with high dust, sand, or salt spray, such as deserts or coastal regions, unless additional protective measures are taken.
- Locations exposed to corrosive gases (such as H₂, SO₂) or explosive atmospheres.
- Spaces with insufficient ventilation, which could lead to overheating.
- Areas within a straight-line distance of 1.55 miles (2.5km) from the coastline. If installation within 1.55 miles (2.5km) of the coastline is unavoidable, consult RENON for a validated technical protection solution.

3.8.3 Installation and Spacing Requirements

- Maintain minimum clearances for proper ventilation and maintenance access:
 - Front: ≥157.5 in (4000 mm)
 - Rear: ≥39.38 in (1000 mm)
 - Left side: ≥1.18 in (30 mm)
 - Right side: ≥1.18 in (30 mm)
- Installation surface must be flat, stable, and capable of bearing the system's full operational weight.
- Ensure the site provides adequate drainage and protection from flooding.

3.8.4 Handling and Installation Precautions

- Utilize appropriate lifting equipment for handling; ensure safe operation following OSHA and applicable local safety standards.
- Avoid impact or collision during transportation and installation.
- It is recommended to use crane lifting. Ensure that the lifting strap specifications match the load, without aging or damage. Slowly lift the junction container 7.9in~11.8in (200mm~300mm) off the ground. Choose a crane with a load capacity $\geq 55,116\text{lb}$ (25,000kg), using four lifting ropes, each rope should have a load capacity suggestion $\geq 17,637\text{lb}$ (8,000kg).
- Comply with provided installation manual.

4. EMS Control

4.1 Control Modes and Authority

The Smart Matrix A supports both local and remote control modes, providing flexibility and security in system operation management. Clear control authority definitions are outlined as follows:

- **Local Control**
Local operation is executed via the BESS container-mounted Human-Machine Interface (LCD touchscreen), enabling on-site manual control, monitoring, and emergency intervention.
- **Remote Control**
Remote operation utilizes secure network communication (Ethernet Modbus TCP/IP) to execute control commands and real-time monitoring. Authorized personnel can remotely start/stop, configure operation modes, adjust operational parameters, and monitor system status.

Priority and Switching between Control Modes:

- The system defaults to Remote Control mode under standard operation conditions.
- Local manual intervention always has higher priority over remote control for safety and emergency situations. Local actions will immediately override any remote commands.
- After local manual control intervention, remote control can be re-enabled by authorized personnel via the local interface.

4.2 Automatic and Manual Control Priority

- BESS operates in Automatic Control Mode during regular system operations, governed by pre-set operation parameters and protection algorithms.
- Local Manual Control mode, initiated at the BESS container interface, will override automatic or remote operations immediately upon activation. This ensures personnel and equipment safety during emergencies or maintenance scenarios.
- Returning the system from Manual Control back to Automatic Control mode must be manually confirmed by authorized operators after ensuring safe operation conditions.

4.3 Core Functions of the Local EMS

The local EMS collects real-time data from battery storage and power distribution via protocols like Modbus, with capability to forward data to third-party systems for coordinated equipment control and remote adjustment. Featuring WiFi/4G dual-mode communication, it supports customizable charge/discharge strategies, rigorous user access control, and safety alarms triggered by voltage/current anomalies, while its intelligent algorithms enable load tracking and demand management to optimize energy costs.

5. Installation Instruction

For detailed installation guidance, cable connection methods, and equipment commissioning procedures, please refer to the **Installation Manual - Smart Matrix A - US**.

(Supplier): _____

Representative:

Signature:

Title:

Date:

(Buyer): _____

Representative:

Signature:

Title:

Date:



6. Revision Table

The document revision history is tracked in the following table:

Revision Number	Date (MM/DD/YYYY)	Description
1.0	Dec 20, 2025	Initial version



Technical Support

Email: support@renon-usa.com

Renon Power USA LLC

580 McIntyre Rd. McKinney, TX 75071

Renon Power Technology B.V.

Rietbaan 10, 2908 LP Capelle aan den IJssel

Renon Power 株式会社

東京都中央区日本橋箱崎町 20-5 VORT 箱崎 5F



LinkedIn



Website